

14 years
World No.1*

JACK

A4C **NTB**

One Day One Threading

Octopus Nine-brain
AI chip

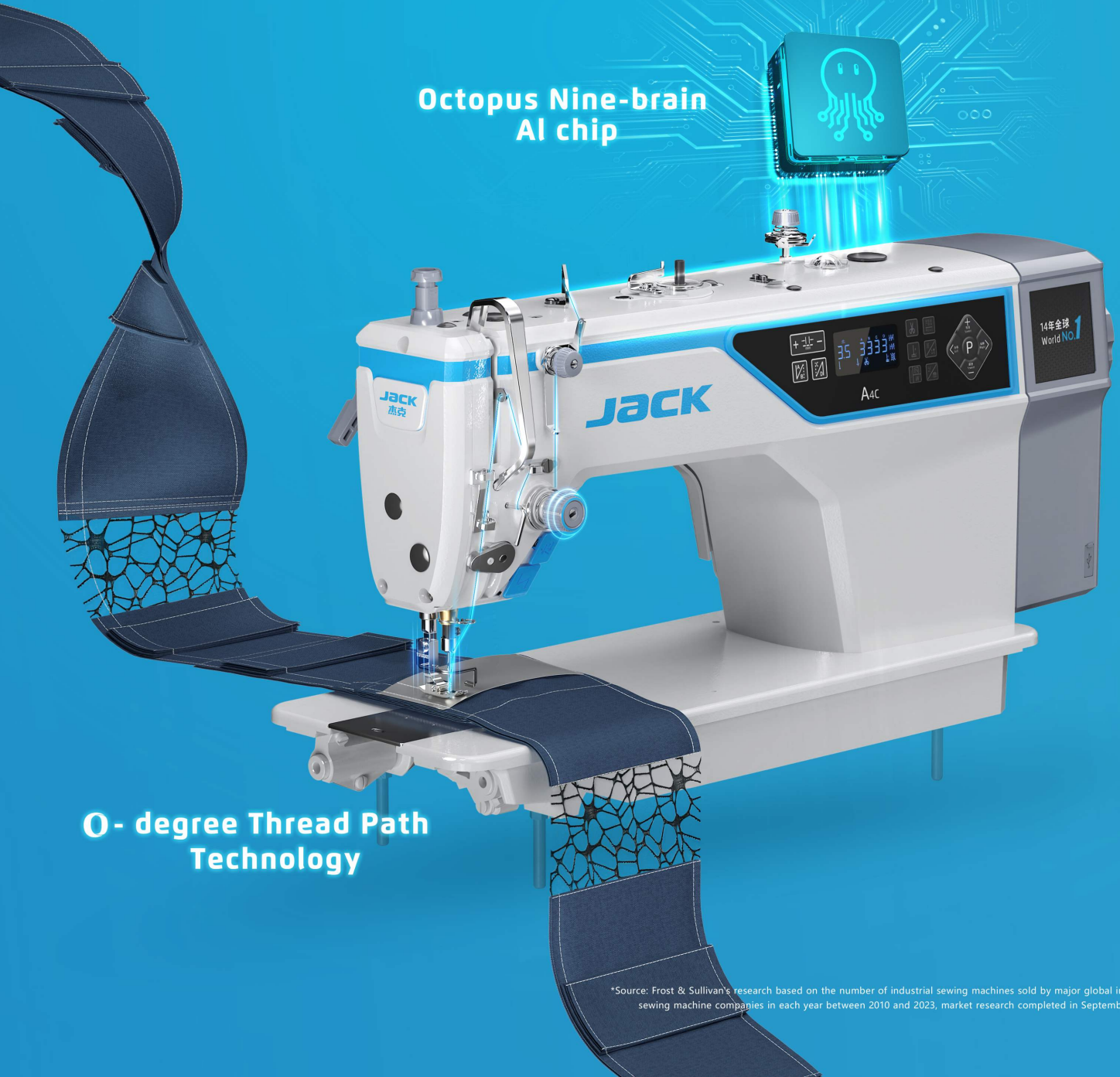
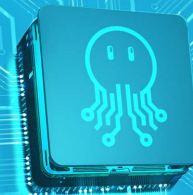

**O-degree Thread Path
Technology**

*Source: Frost & Sullivan's research based on the number of industrial sewing machines sold by major global industrial sewing machine companies in each year between 2010 and 2023, market research completed in September 2024.

NTB System

The **Octopus Nine - brain AI chip** calculates at high speed to generate the optimal fabric - feeding force. It collaborates with the **0 - degree Thread Path Technology** to precisely feed, wind, and catch the thread, achieving a perfect coordination among mechanisms such as thread - taking, thread - catching, and fabric - feeding.

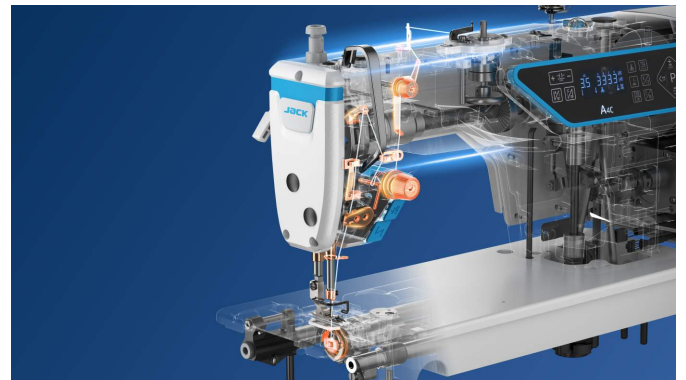
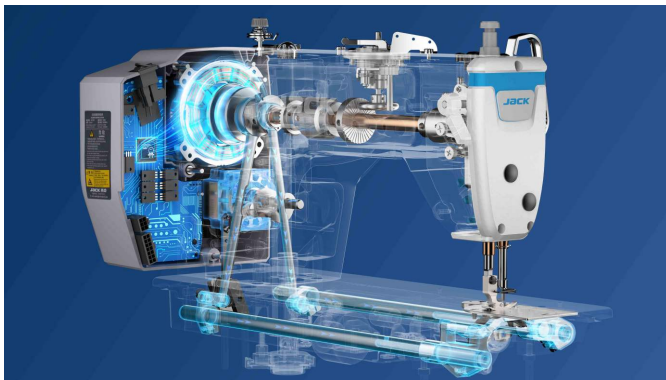
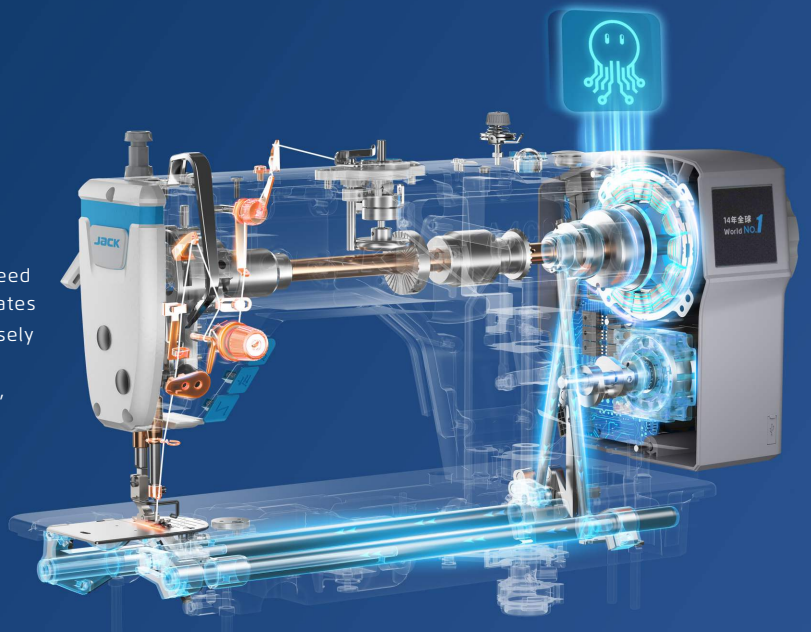

• **Octopus Nine - brain AI chip:**
Precisely outputs the fabric - feeding force, with **200,000** fabric samples + **10,000** times/second computing power.

• **0 - degree Thread Path Technology:**
Precise thread handling • Precise thread catching
Jack's exclusive thread - passing technology reduces thread tension by **30%**.

Customer Value

The comprehensive thread - breakage rate is reduced by **80%**

The overall output increases by approximately **5%**

Technical Parameters

Model	Needle	Thread number	Stitch length (mm)	Height of presser foot(mm)	Max. sewing speed (S.p.m)	Thin materials	Medium - thick materials	Thick materials	volume (mm)	Weight (kg)
A4C-C	DBx1 11-18#	2	5	5-13	5000	✓	✓		695x295x550	36/42
A4C-C-7	DBx1 11-18#	2	7	5-13	3500	✓	✓		695x295x550	36/42
A4C-CH-7	DPx5 18-21#	2	7	5-13	3500			✓	695x295x550	36/42
A4C-CHL-7	DPx5 18-21#	2	7	5-13	3500			✓	695x295x550	36/42